

AutoCAD® Self-paced Learning Modules

AutoCAD 3D

Module 25

Creating 2D Drawings from Solid Models

Learning Outcomes

When you have completed this module, you will be able to:

1. Describe and apply the SOLVIEW, SOLDRAW and SOLPROF commands to convert a solid model into a 2D drawing complete with hidden lines and dimensions.

Creating 2D Drawings from Solid Models

After an object is constructed as a solid 3D model there are AutoCAD commands and features available to create and dimension a 2D multiview drawing to the plotting stage. Before you go any farther in this module, you must know and understand the following concepts:

1. Creating and modifying AutoCAD layout drawings.
2. Working in paper space.
3. Creating and editing a viewports and setting their scale.

The concepts listed above are covered in the AutoCAD 2D Modules 39 and 40. If necessary, go back and reread or redo those two modules.

AutoCAD Command: **SOLVIEW**

The SOLVIEW command is used to create views and the necessary layers of a 3D solid model.

Shortcut: none

Important: Before you use the SOLVIEW command, ensure that the shademode is in 2D Wireframe and that the Hidden linetype is loaded into the drawing.

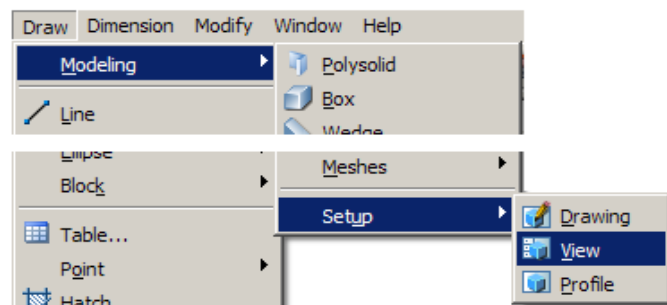

2007-2010

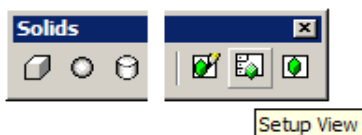

2000-2002



2004-2006

AutoCAD Command: **SOLDRAW**

The SOLDRAW command is used to convert views created by the SOLVIEW command by projecting the 3D objects onto a 2D plane and changing hidden objects onto the hidden layer.

Shortcut: none

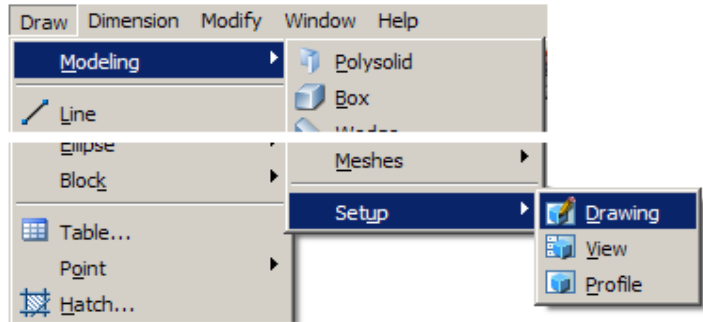

2007-2010



2004-2006



2000-2002

AutoCAD Command: **SOLPROF**

The SOLPROF command is used to create a profile of edges of straight and curved surfaces of a solid model as it is viewed from a selected viewpoint.

Shortcut: none

Important: Before you use the SOLPROF command, ensure that the shademode is in 2D Wireframe and that the Hidden linetype is loaded into the drawing.

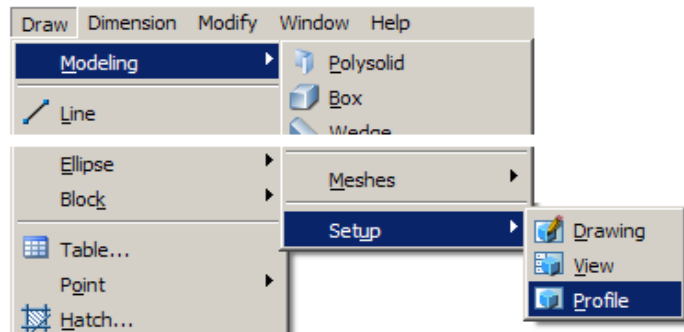

2007-2010



2004-2006

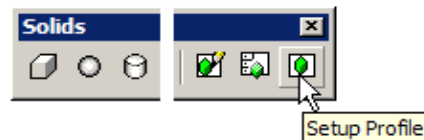

2000-2002

**WORK
ALONG**

Creating 2D Drawings from Solid Models

Step 1 Using the NEW command, start a new drawing using template Module Template 3D English.

Step 2 Save and name the drawing AutoCAD 3D Workalong 25-1.

Step 3 Create layers Construction, Model and Solid as shown in Figure Step 3.

Status	Name	On	Freeze	Lock	Color	Linetype
<input checked="" type="checkbox"/>	0				white	Continuous
	Construction				253	Continuous
	Defpoints				white	Continuous
	Hatch				white	Continuous
	Key				white	Continuous
	Model				red	Continuous
	Solid				151	Continuous

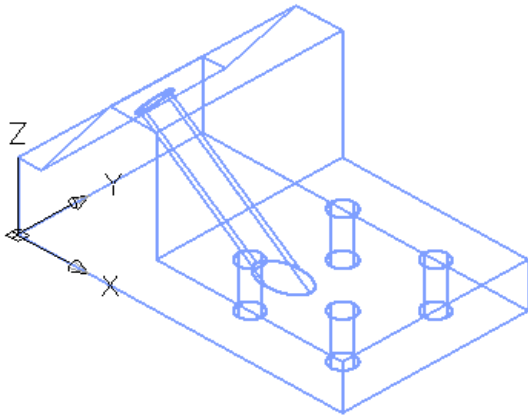
Figure Step 3**Figure Step 5**

Step 4 Set the UCS as World, the view as SE Isometric, the shademode to 2D Wireframe and insert the block AutoCAD 3D Workalong 25-1.

Step 5 Explode the block and change the solid model to layer Solid. Check to ensure the block was exploded and your model is a 3D solid. It should now appear as shown in Figure Step 5.

Step 6 Load the linetype Hidden into the drawing using the LINETYPE command. See Figure Step 6.

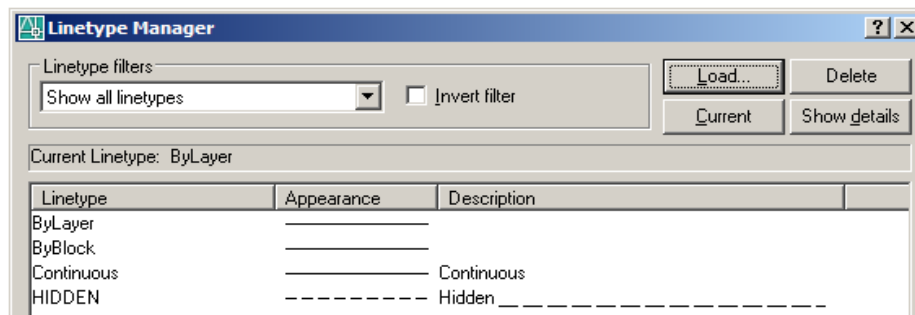
**Figure Step 6****MUST
KNOW**

VERY IMPORTANT

Before you use either the SOLVIEW and the SOLPROF commands, ensure that the shademode is in 2D Wireframe and that the Hidden linetype is loaded into the current drawing.

Step 7 Enable layout Module Template Layout D as shown in Figure Step 7.

Step 8 Enter the SOLVIEW command shown below to create the top view of the model. See Figure Step 8.

Command: **SOLVIEW**

Enter an option [Ucs/Ortho/Auxiliary/Section]: **U**

(Enter U to draw the view from the UCS.)

Enter an option [Named/World/?/Current]

<Current>:

(Accept the default Current.)

Enter view scale <1.0000>:

(Accept the scale of 1.)

Specify view center: **P1**

(Select a location for the center of the view.)

Specify view center <specify viewport>:

(Press Enter to accept the location.)

Specify first corner of viewport: **P2**

Specify opposite corner of viewport: **P3**

Enter view name: **Top**

(The view must be named.)

Command:

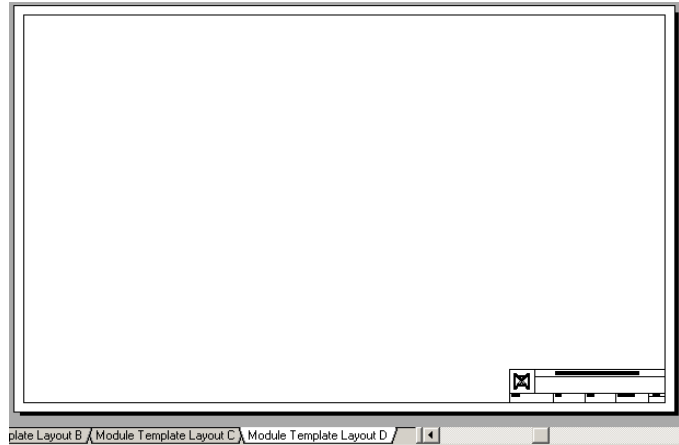

Figure Step 7

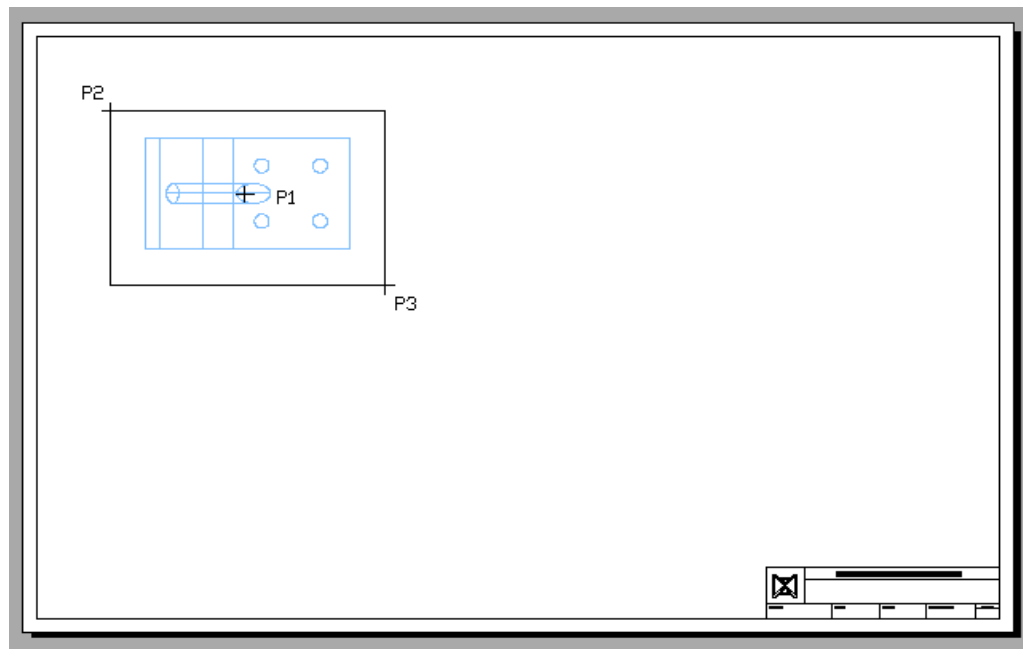

Figure Step 8

Step 9 Enter the SOLVIEW command again but this time, create the front view by projecting orthographically from the top view. Doing it that way, the two views will be aligned. See Figure Step 9A and 9B.

Command: **SOLVIEW**

Enter an option [Ucs/Ortho/Auxiliary/Section]: **O**

Specify side of viewport to project: (*mid*)

Specify view center: **P4**

Specify view center <specify viewport>:

Specify first corner of viewport: **P5**

Specify opposite corner of viewport: **P6**

Enter view name: **Front**

Command:

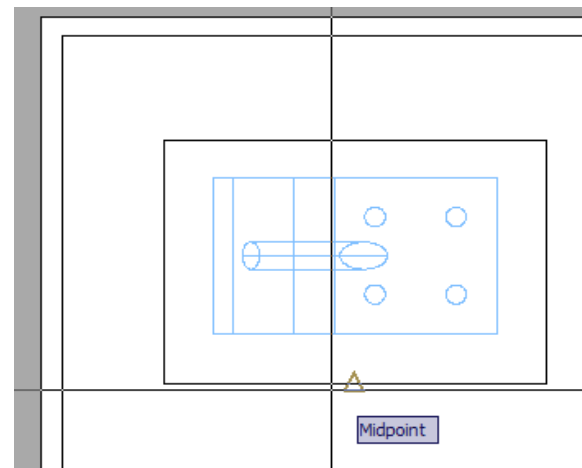

Figure Step 9A

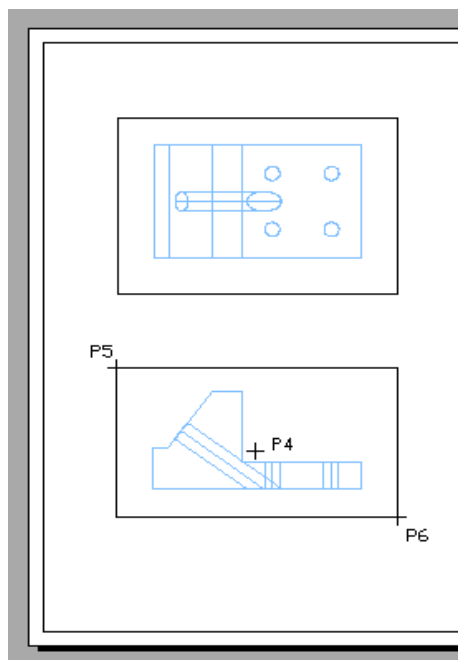

Figure Step 9B

Step 10 Using what you just learned, create the right side view and name it Right as shown in Figure Step 10A and 10B.

Command: **SOLVIEW**

Enter an option [Ucs/Ortho/Auxiliary/Section]: **O**

Specify side of viewport to project: (*mid*)

Specify view center:

Specify view center <specify viewport>:

Specify first corner of viewport:

Specify opposite corner of viewport:

Enter view name: **Right**

Enter an option [Ucs/Ortho/Auxiliary/Section]:

Command:

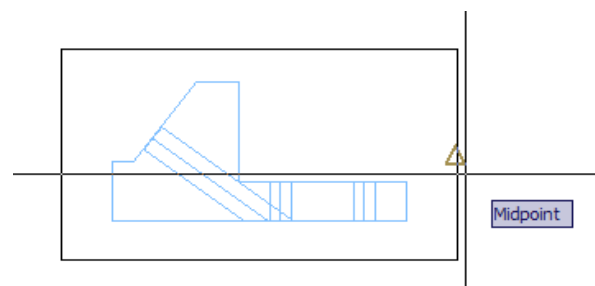

Figure Step 10A

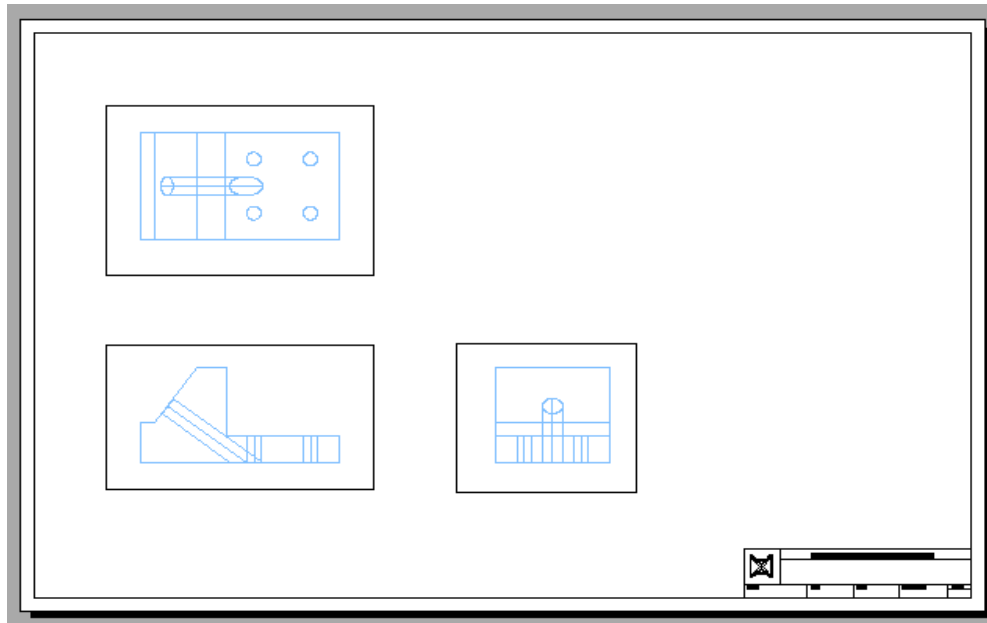

Figure Step 10B

Step 11 Using what you learned in AutoCAD 2D, use the MVIEW command to create a view in the top right corner of the drawing. Change the scale of the view to 1 and the orientation to SE Isometric. Pan the view to center it. See Figure Step 11.

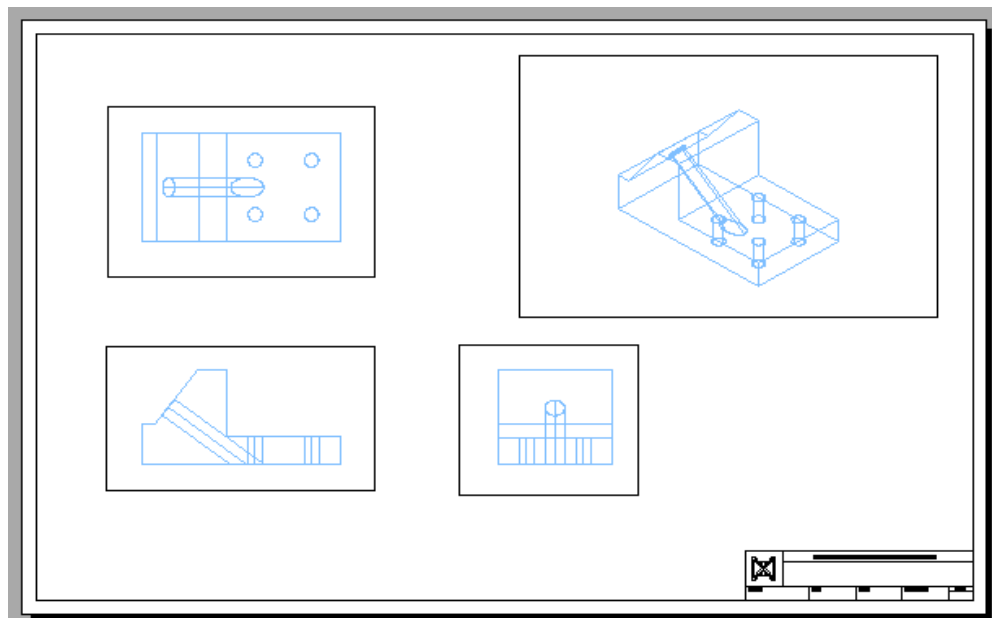

Figure Step 11

Step 12 Using the UNITS command, set the length precision to 8 decimal places. Open the Properties window and select all four viewports as shown in Figure Step 12. Check that the scale of all views is set to 1, then lock their display.

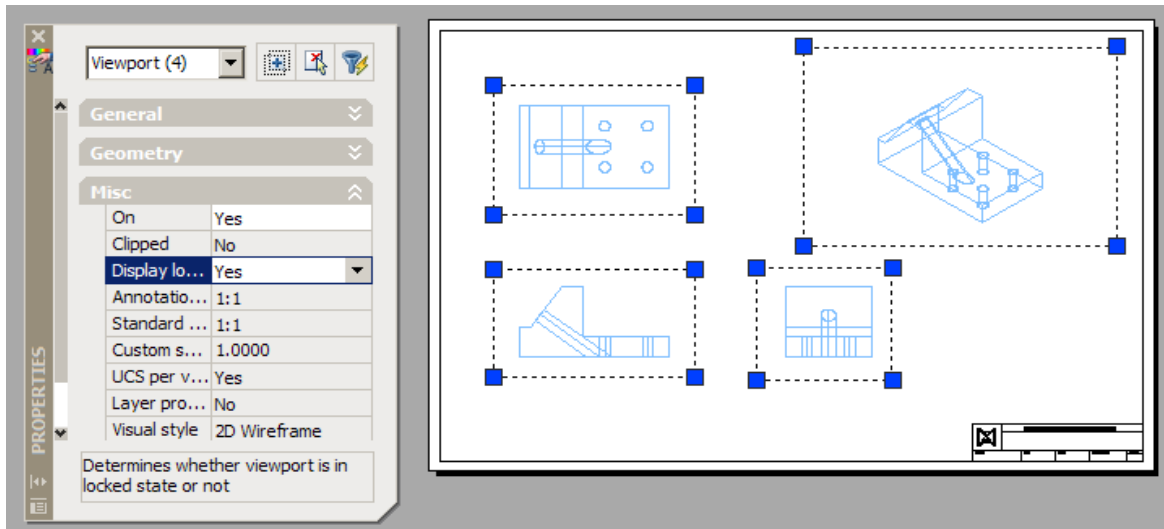

Figure Step 12

Step 13 Enter the SOLDRAW command shown below to change the views to 2D. See Figure Step 13A and 13B.

Command: **SOLDRAW**

Select viewports to draw..

Select objects: 1 found

Select objects: 1 found, 2 total

Select objects: 1 found, 3 total

(Select the three multiview viewports.)

Select objects:

One solid selected.

One solid selected.

One solid selected.

Command:

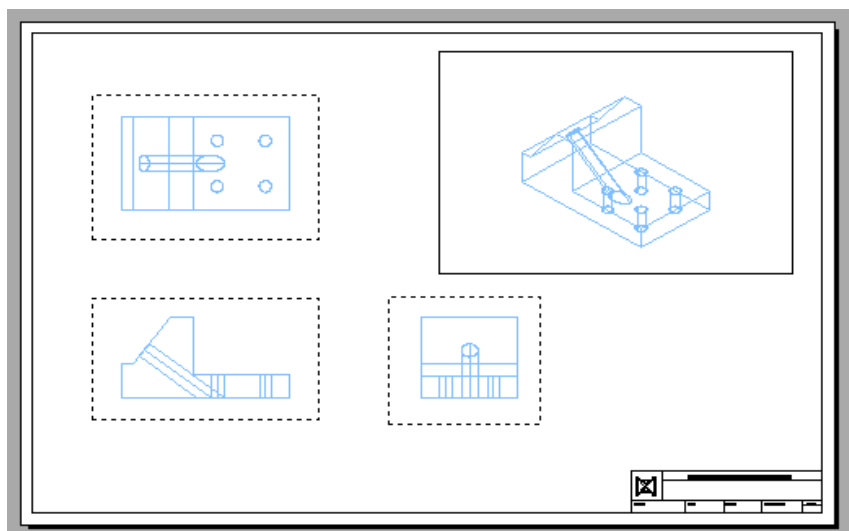

Figure Step 13A

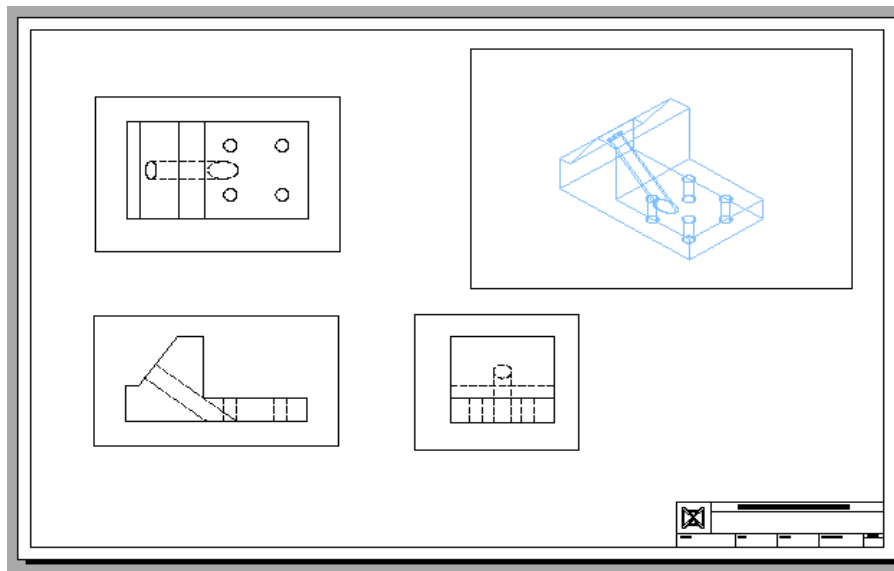

Figure Step 13B

Step 14 Go to model mode and select the isometric view as the current viewport. Enter the SOLPROF command as shown below. See Figure Step 14A and 14B.

Command: **SOLPROF**

Select objects: 1 found

(Select the solid model.)

Select objects:

Display hidden profile lines on separate layer? [Yes/No]

<Y>:

(Select the default.)

Project profile lines onto a plane? [Yes/No] <Y>:

(Select the default.)

Delete tangential edges? [Yes/No] <Y>:

(Select the default.)

Enter an option

Command:

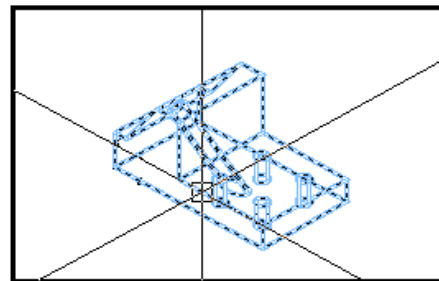

Figure Step 14A

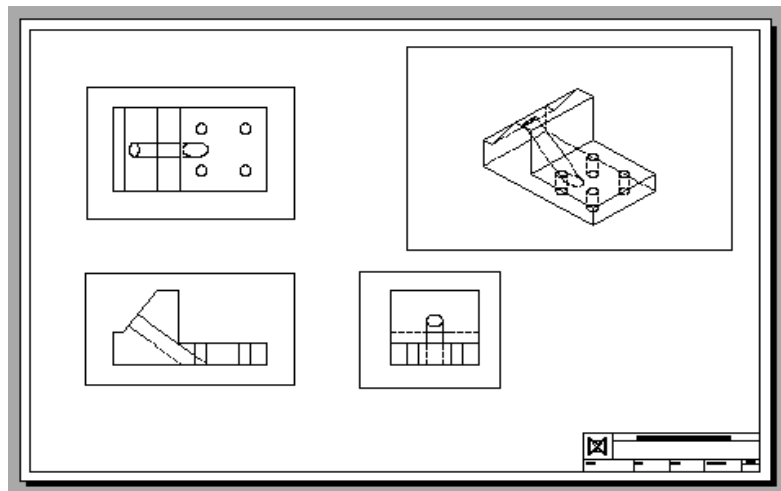

Figure Step 14B

Step 15 Change the colors of the layers to match Figure Step 15.

Step 16 Turn Layer VPORT off and your completed drawing will appear as shown in Figure Step 16.

Step 17 Save and close the drawing.

Status	Name	On	Freeze	Lock	Color	Linetype
	0	On	Off	Off	white	Continuous
	Defpoints	On	Off	Off	white	Continuous
	Dimensions	On	Off	Off	white	Continuous
	Front-DIM	On	Off	Off	white	Continuous
	Front-HID	On	Off	Off	blue	HIDDEN
	Front-VIS	On	Off	Off	red	Continuous
	Key	On	Off	Off	magenta	Continuous
	Layout ...tleblock	On	Off	Off	white	Continuous
	PH-18C4	On	Off	Off	blue	HIDDEN
	PV-18C4	On	Off	Off	red	Continuous
	Right-DIM	On	Off	Off	white	Continuous
	Right-HID	On	Off	Off	blue	HIDDEN
	Right-VIS	On	Off	Off	red	Continuous
	Solid	Off	Off	Off	141	Continuous
	Top-DIM	On	Off	Off	white	Continuous
	Top-HID	On	Off	Off	blue	HIDDEN
	Top-VIS	On	Off	Off	red	Continuous
✓	VPORTS	Off	Off	Off	white	Continuous

Figure Step 15

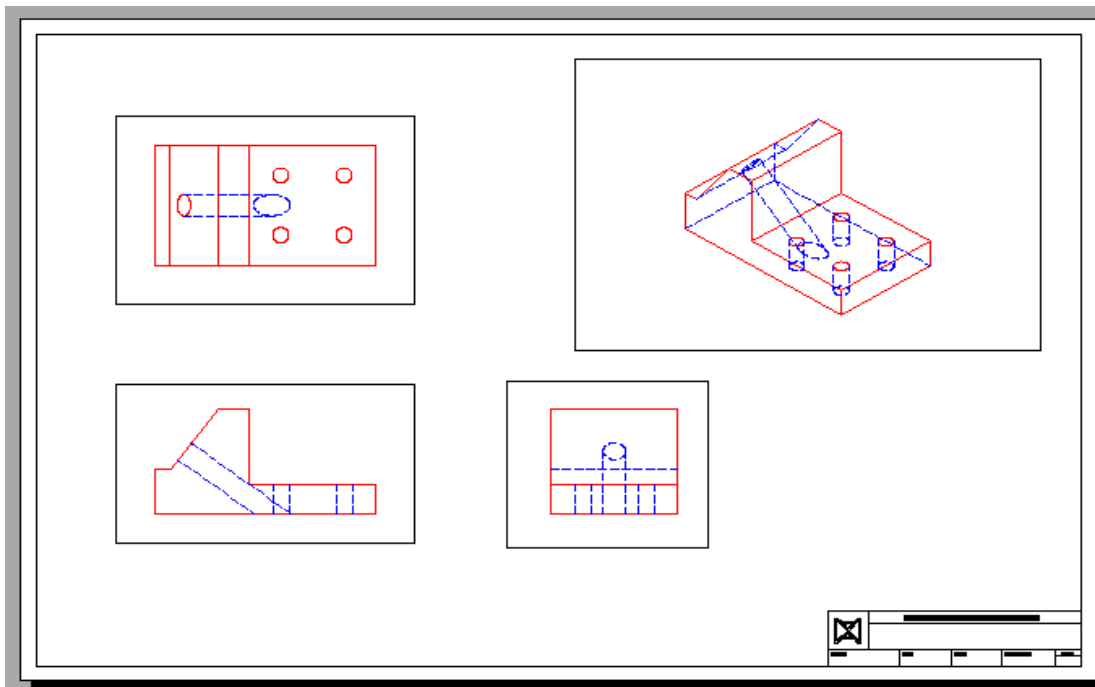

Figure Step 16

The Key Principles in Module 25

1. Before you use the SOLVIEW and the SOLPROF commands, ensure that the shademode is in 2D Wireframe and that the Hidden linetype is loaded into the drawing.

Lab Exercise 25-1**Time Allowed: 45 Min.**

Name	Template	Units
AutoCAD 3D Lab 25-1	3D Layout English	Inches

Instructions:

Step 1 Draw the object shown on page 25-11 as a solid model.

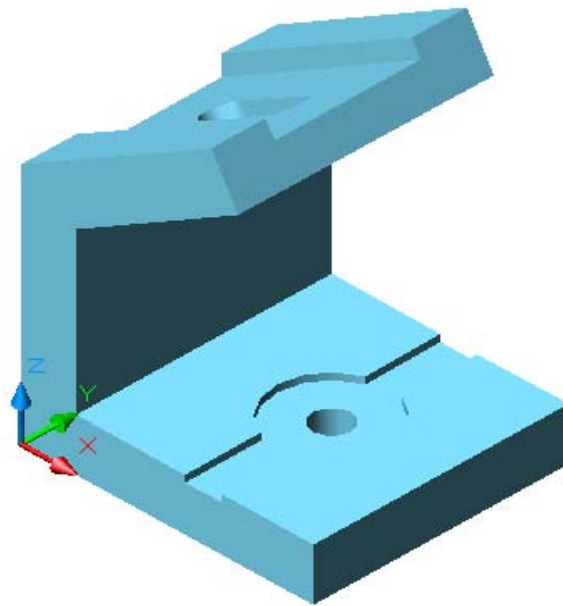

The Solid Model - SE Isometric View

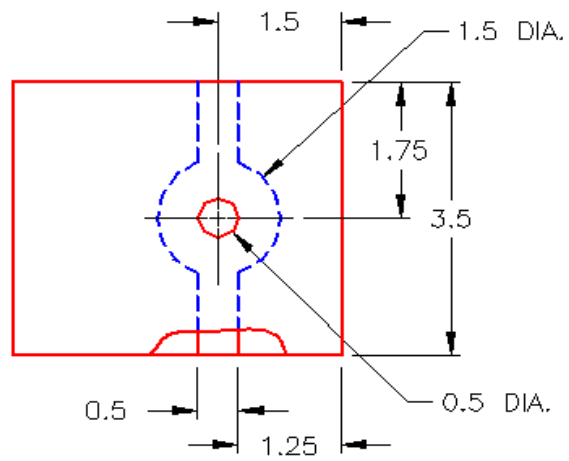
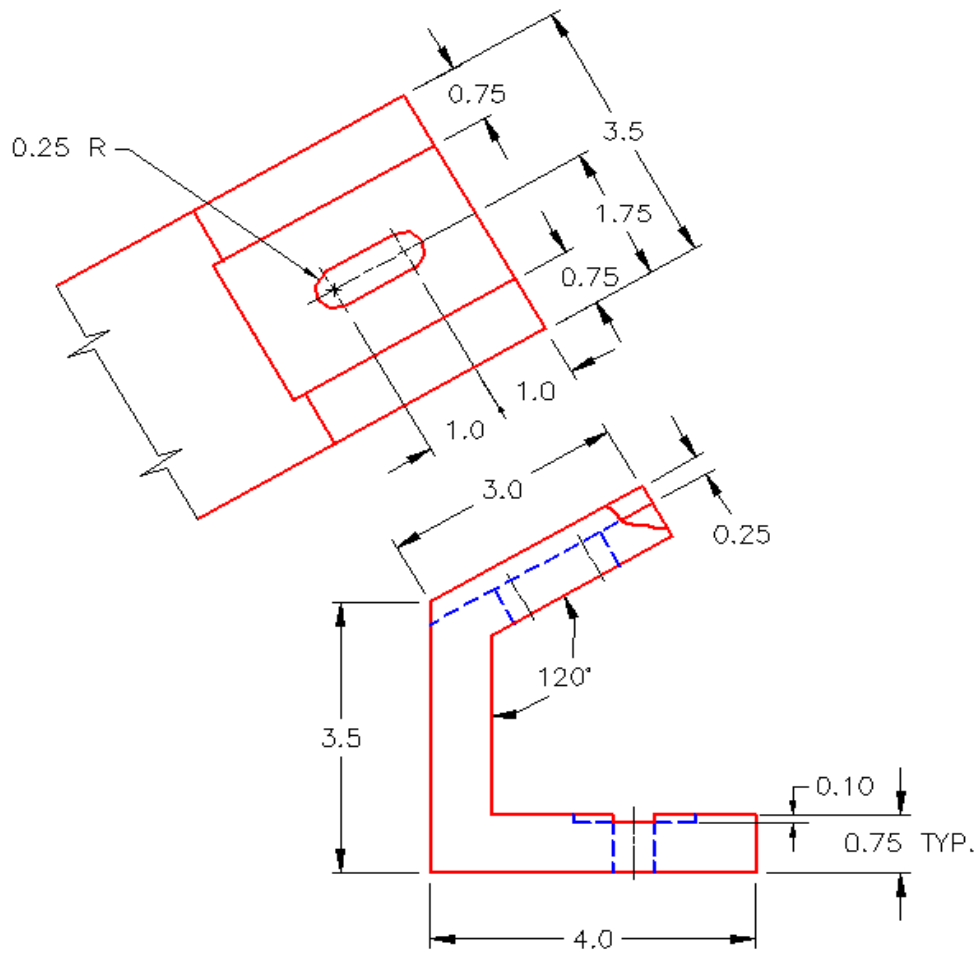

Multiview Drawing

Step 2 On Module Template Layout D and using the command SOLVIEW, create the three multiviews as shown in the drawing below. The scale of the view set to 1.5:1 and lock their display.

Step 3 Use the SOLDRAW command to change the views to 2-dimensional.

Step 4 Using the MVIEW command, create two views and set their view to SE Isometric. Scale the views to 1:1 and lock their display. Set one of the views to display shaded.

Step 5 Change the color of the layers to Red for object lines and Blue for the hidden lines. (Hint: Page 25-9)

Step 6 Use the SOLPROF command to create the hidden lines in the isometric view.

Step 7 In paper space, add a few dimension as shown below.

Step 8 Fill in the titleblock in paper space.

Step 9 Turn layer VPORT off.

